

HS-1500A-HD Technical Data Sheet

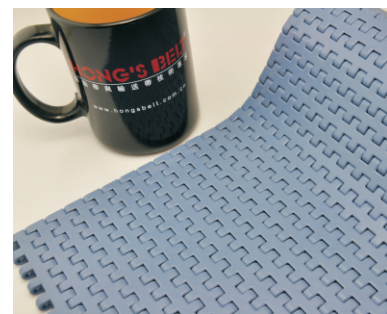
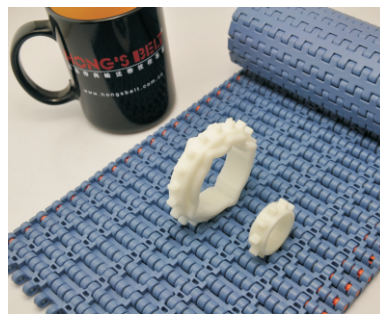
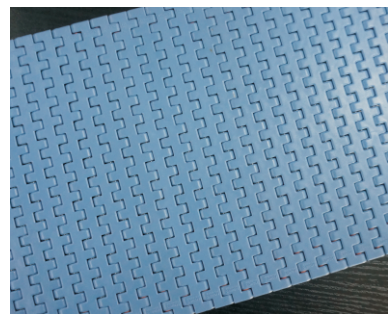
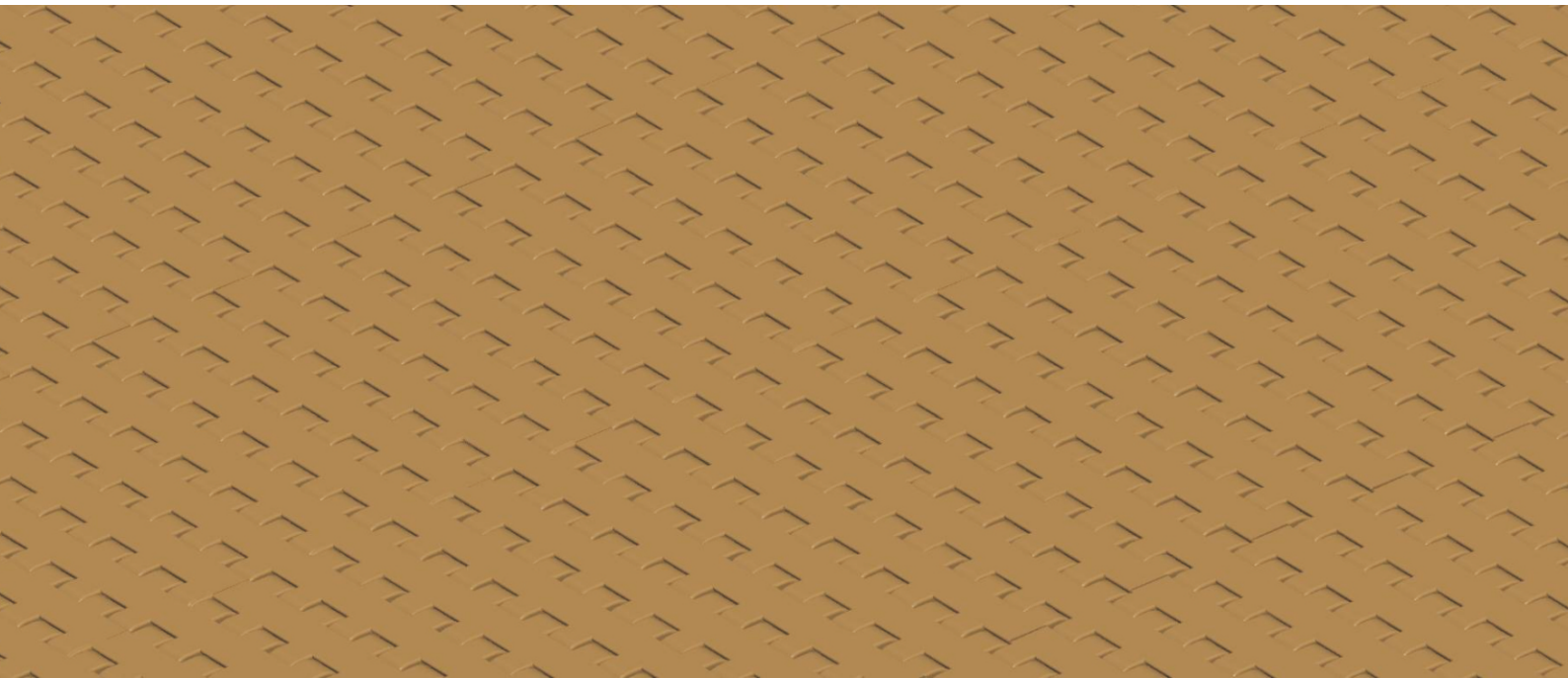

Pitch: 12.7mm Minimum Width: 205.5mm Open Area: 0% Approved: FDA Rod: Ø4.5mm Flight: Yes Side Guard: No Curve: No	
--	--

Data

Belt Material	Belt Strength			Temperature		Belt Weight (Kg/M ²)
	Straight		Curve	°C (min.)	°C (max.)	
	Kg/M(BW)	N/M(BW)				
Polypropylene	1020	10200	--	1	100	4.0
Polyethylene	860	8600	--	-60	60	4.3
Acetal	1650	16500	--	-40	80	6.9
Nylon	1520	15200	--	1	180	5.8

BW – Belt Width

Color Table

Polypropylene					Polyethylene					Acetal					Nylon				
W	G	N	DB	B	W	G	N	DB	B	W	G	N	DB	B	W	G	N	DB	B
●	●						●			●			●	●				●	

W-White, G-Gray, N-Nature, DB-Darkbrown, B-Blue

Friction Table

Belt Material	Friction Wear strips & Products							
	UHMW	HDPE	Steel	Glass	SUS	Plastic	Cardboard	Aluminum
Polypropylene	0.32	0.24	0.15	0.09	0.13	0.08	0.15	0.25
Polyethylene	0.13	0.11	0.26	0.19	0.31	0.16	0.21	0.41
Acetal	0.11	0.09	0.27	0.16	0.26	0.15	0.19	0.28
Nylon	0.18	0.13	0.25	0.16	0.26	0.16	0.19	0.27

SUS – Stainless Steel

Equivalent type with other Brand

Brand Name	Intralox	UNI	Rexnord	MCC	Habasit	KVP
Series & Type	1100	M-SNB	500	500	M1100	SM605
	1500				M1200	CH605

The above content is only for reference.

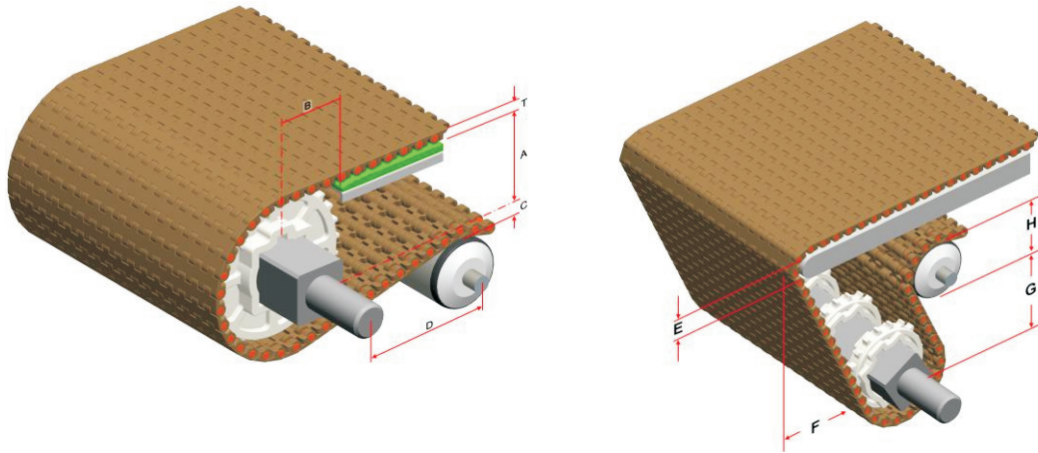

Conveyor Frame Dimensions

Unit : mm

No. Teeth	A (Min.)	B (Min.)	C (Max.)	D (Min.)	E (Min.)	H(Min.)	T
10	15.5	30.5	14.5	100	Ø 20	Ø 60	10
19	34	49	33	100	Ø 20	Ø 60	
24	45.25	60.25	44.25	130	Ø 20	Ø 60	
28	52.5	67.5	51.5	130	Ø 20	Ø 60	

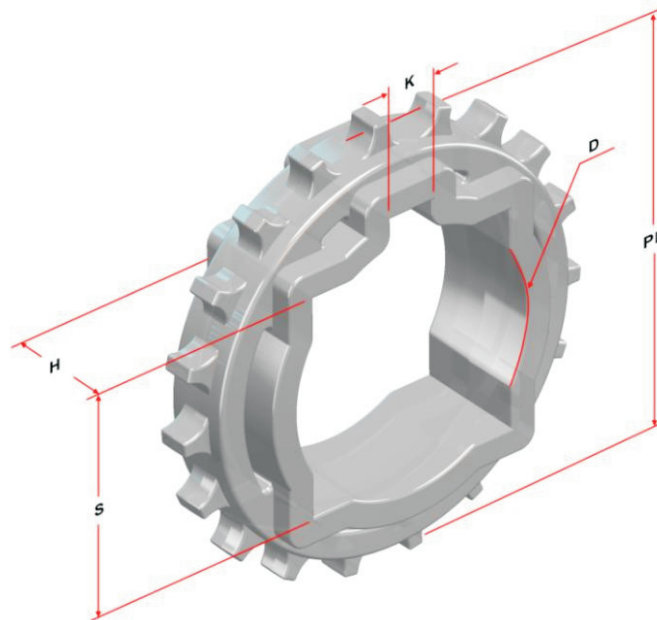

Sprocket Dimensions

Unit: mm

No. Teeth	PD	S	D	H	K
10	41	--	20/25	12	6X6
19	78	38.5/40.5	25/25.4/30.5	20	8X8
24	100.5	38.5/40.5	25.4	30	8X8
28	115	38.5/40.5	25/25.4/30.5/42.5	30	8X8