

HS-501EL Technical Data Sheet

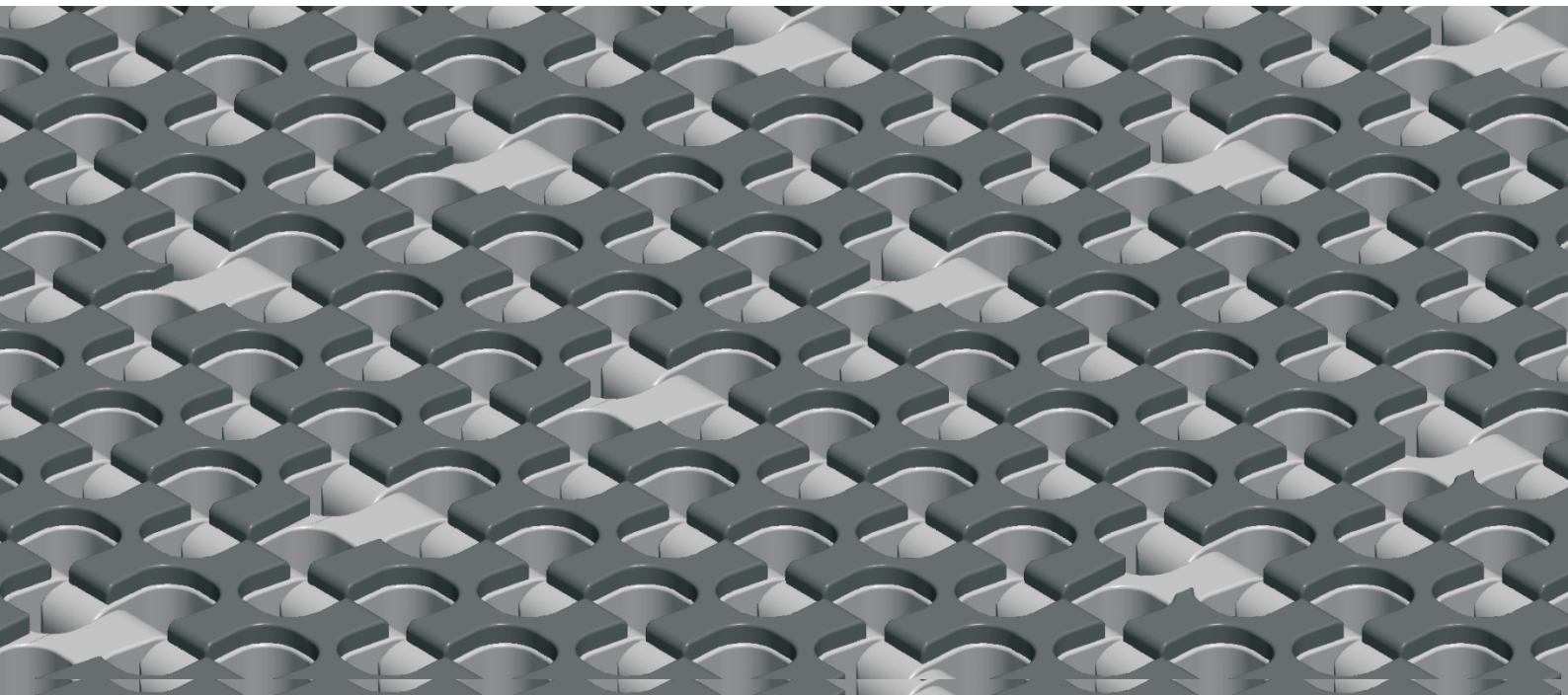

Pitch: 25.4mm Minimum Width: 172mm Open Area: 35% Approved : FDA Rod: Ø 4.9mm Flight: Yes Side Guard: No Curve : No	
--	--

Data

Belt Material	Belt Strength		Curve	Temperature		Belt Weight (Kg/M ²)
	Straight			°C (min.)	°C (max.)	
	Kg/M(BW)	N/M(BW)				
Polypropylene	1060	10600	--	1	70	7.2
BW – Belt Width						

Color Table

Polypropylene					Polyethylene					Acetal					Nylon				
W	G	N	DB	B	W	G	N	DB	B	W	G	N	DB	B	W	G	N	DB	B
●	●																		

W-White, G-Gray, N-Nature, DB-Dark brown, B-Blue

Friction Table

Belt Material	Friction Wear strips & Products							
	UHMW	HDPE	Steel	Glass	SUS	Plastic	Cardboard	Aluminum
Polypropylene	0.32	0.24	0.15	0.09	0.13	0.08	0.15	0.25
Polyethylene	0.13	0.11	0.26	0.19	0.31	0.16	0.21	0.41
Acetal	0.11	0.09	0.27	0.16	0.26	0.15	0.19	0.28
Nylon	0.18	0.13	0.25	0.16	0.26	0.16	0.19	0.27

SUS – Stainless Steel

Equivalent type with other Brand

Brand Name	Intralox	UNI	Rexnord	MCC	Habasit	KVP
Series & Type	1400	SNB	1005		2400	610
	1600/1650	CNB	1010		2500	208CL
	900	OPB	7700		2600	20835

The above content is only for reference.

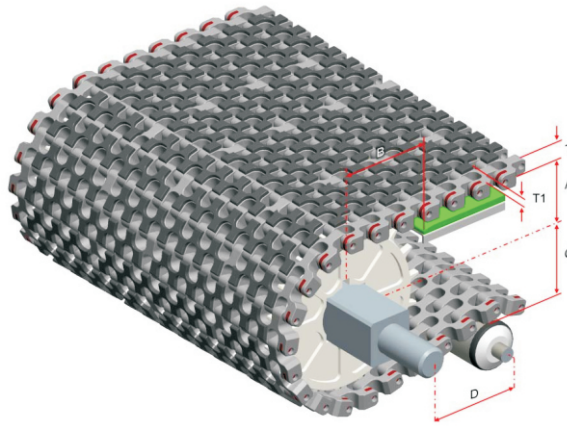

Conveyor Frame Dimensions

Unit : mm

No. Teeth	A (Min.)	B (Min.)	C (Max.)	D (Min.)	T	T1
12 / 12-2R	43.5	60	41	200	13	3
15-2R	56.25	72.75	53.75	200		
18 / 18-2R	67.5	84	65	200		
21-2R	80	96.5	77.5	200		
24 / 24-2R	93.5	110	91	250		

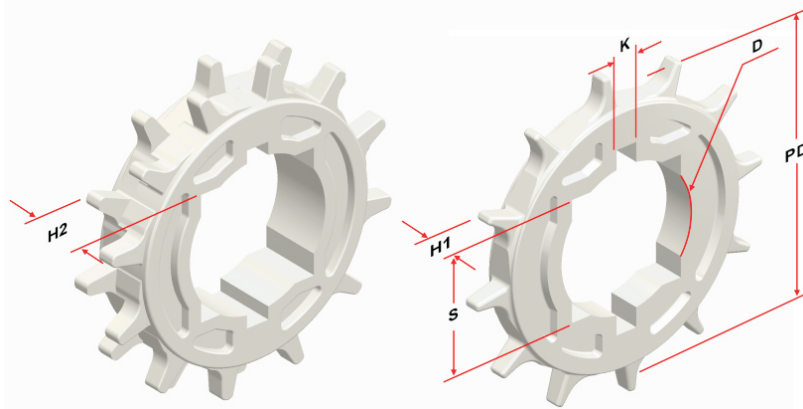

Sprocket Dimensions

Unit: mm

No. Teeth	PD	S	D	H1	H2	K
12	100	25.4/38.5/39/40..5	25.4/30.5/35.5/46.5/47.5	18	--	7X7
18	148	38.5/40..5	25.4/30.5/31.75/36.5/40.5/45.5/47.5	18	--	8X8
24	200	38.5/40.5/50.5/60.5	--	30	--	--
12-2R	100	38.5/40..5	25.4/30.5/45.5/47.5	--	20	8X8
15-2R	125.5	38.5/40..5	25.4/30.5/45.5/47.5	--	20	8X8
18-2R	148	38.5/40.5/45.5/60.5	30.5/40.5	--	20	8X8
21-2R	173	38.5/40.5	45.5	--	35	8X8
24-2R	200	38.5/40.5/60.5	--	--	35	--