

HS-3900C Technical Data Sheet

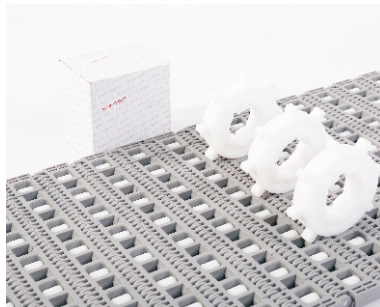

Pitch: 50.8mm
 Minimum Width: 152mm
 Open Area: 14%
 Approved: FDA
 Rod: Ø 5.8mm
 Flight: No
 Side Guard: No
 Curve : No

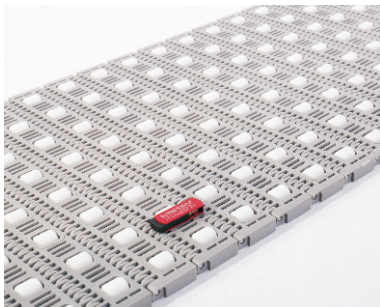
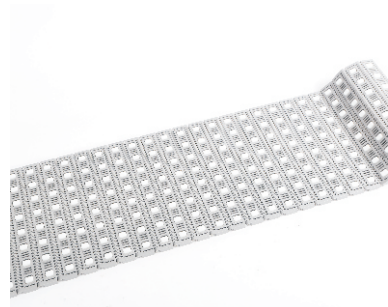
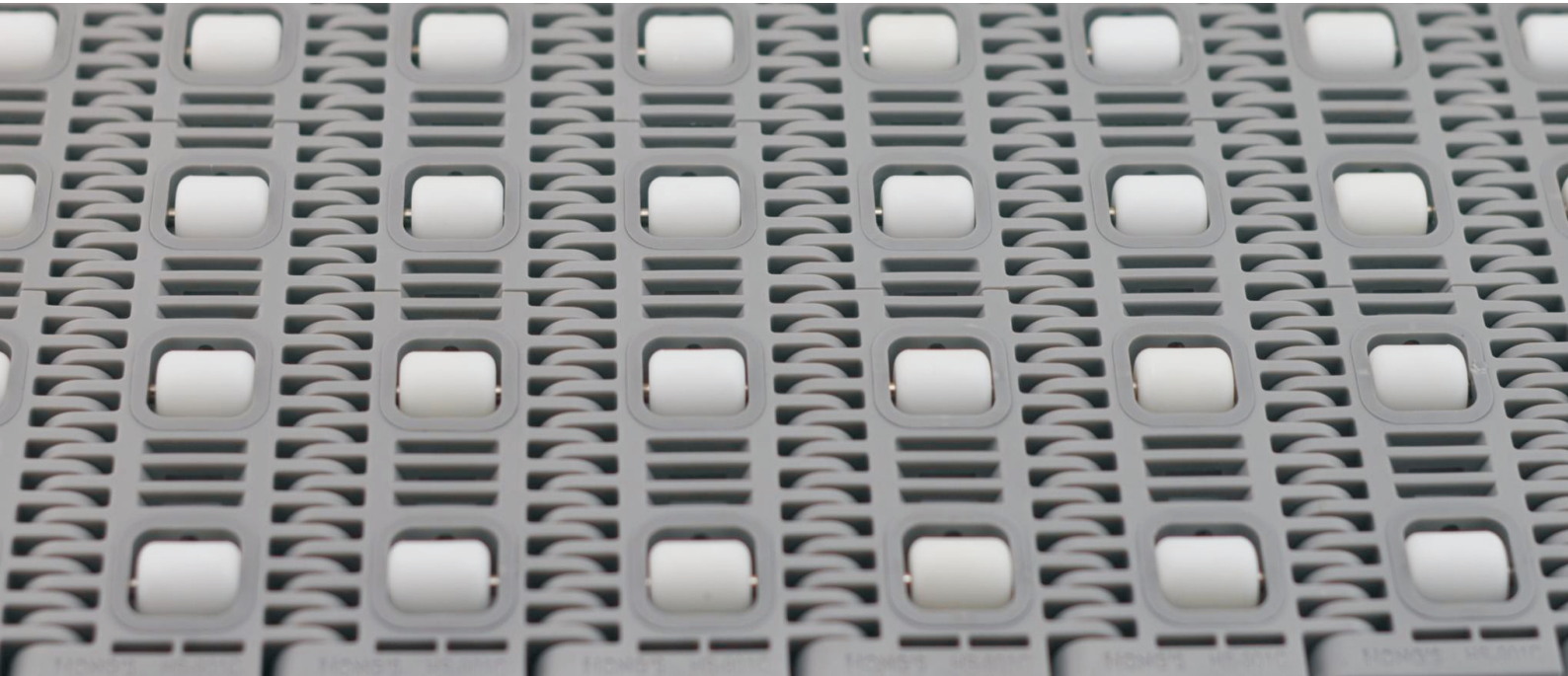
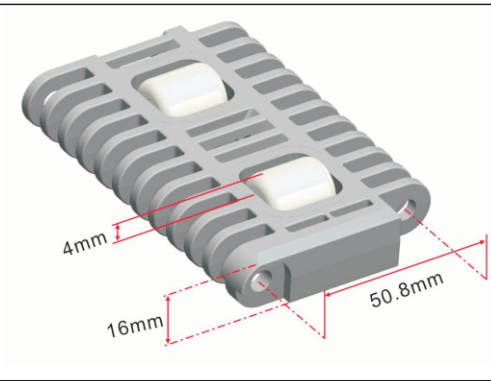

Data

Belt Material	Belt Strength			Temperature		Belt Weight (Kg/M ²)
	Straight		Curve	°C (min.)	°C (max.)	
	Kg/M(BW)	N/M(BW)				
Polypropylene	3500	35000	--	1	100	10.7
Polyethylene	2600	26000	--	- 60	60	--
Acetal	4760	47600	--	- 40	80	--

BW – Belt Width

Color Table

Polypropylene					Polyethylene					Acetal				
W	G	N	DB	B	W	G	N	DB	B	W	G	N	DB	B
●	●						●			●			●	●

W-White, G-Gray, N-Nature, DB-Dark brown, B-Blue

Friction Table

Belt Material	Friction Wear strips & Products							
	UHMW	HDPE	Steel	Glass	SUS	Plastic	Cardboard	Aluminum
Polypropylene	0.32	0.24	0.15	0.09	0.13	0.08	0.15	0.25
Polyethylene	0.13	0.11	0.26	0.19	0.31	0.16	0.21	0.41
Acetal	0.11	0.09	0.27	0.16	0.26	0.15	0.19	0.28

SUS – Stainless Steel

Equivalent type with other Brand

Brand Name	Intralox	UNI	Rexnord	MCC	Habasit	KVP
Series & Type	200	DPB	2000	2000	M5000	620
	400	SNB	2010		M5100	
	800/850	MPB	6390			

The above content is only for reference.

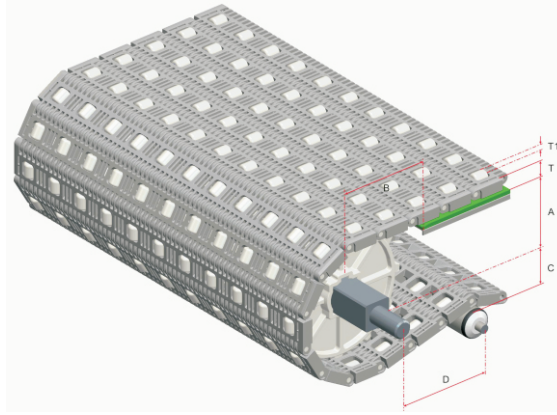

Conveyor Frame Dimensions

Unit : mm

No. Teeth	A (Min.)	B (Min.)	C (Max.)	D (Min.)	T	T1
6	37.5	55.5	33.5	200	16	4
8 / 8-Split	56.5	74.5	52.5	250		
10	72	90	68	250		
12	90	108	86	300		
16	121.75	139.75	117.75	300		
17	130	148	126	300		

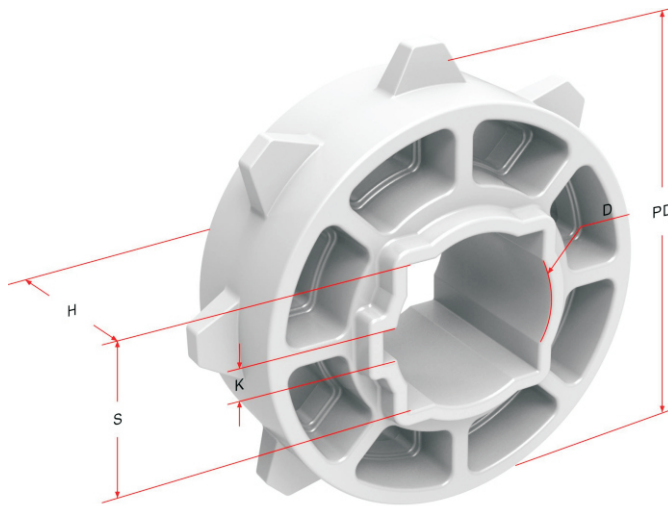

Sprocket Dimensions

Unit: mm

No. Teeth	PD	S	D	H	K
6	91	38.5	--	38	--
8	129	35.5/40.5	--	38	--
8-Split	129	38.5/40.5	--	38	--
10	160	38.2/40.2/50.2/60.2/70.5	--	38	--
12	196	38.5/40.5/50.5/60.5/63.5/70.5	40	49	12×8
16	259.5	60.5/80.5/90.5	---	49	---
17	276	120	--	48.5	--