

HS-1800D Technical Data Sheet

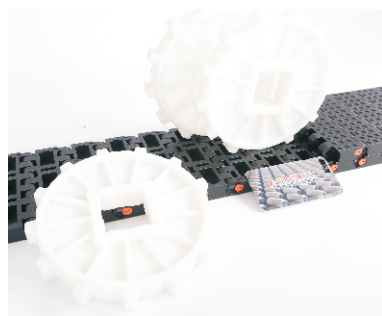
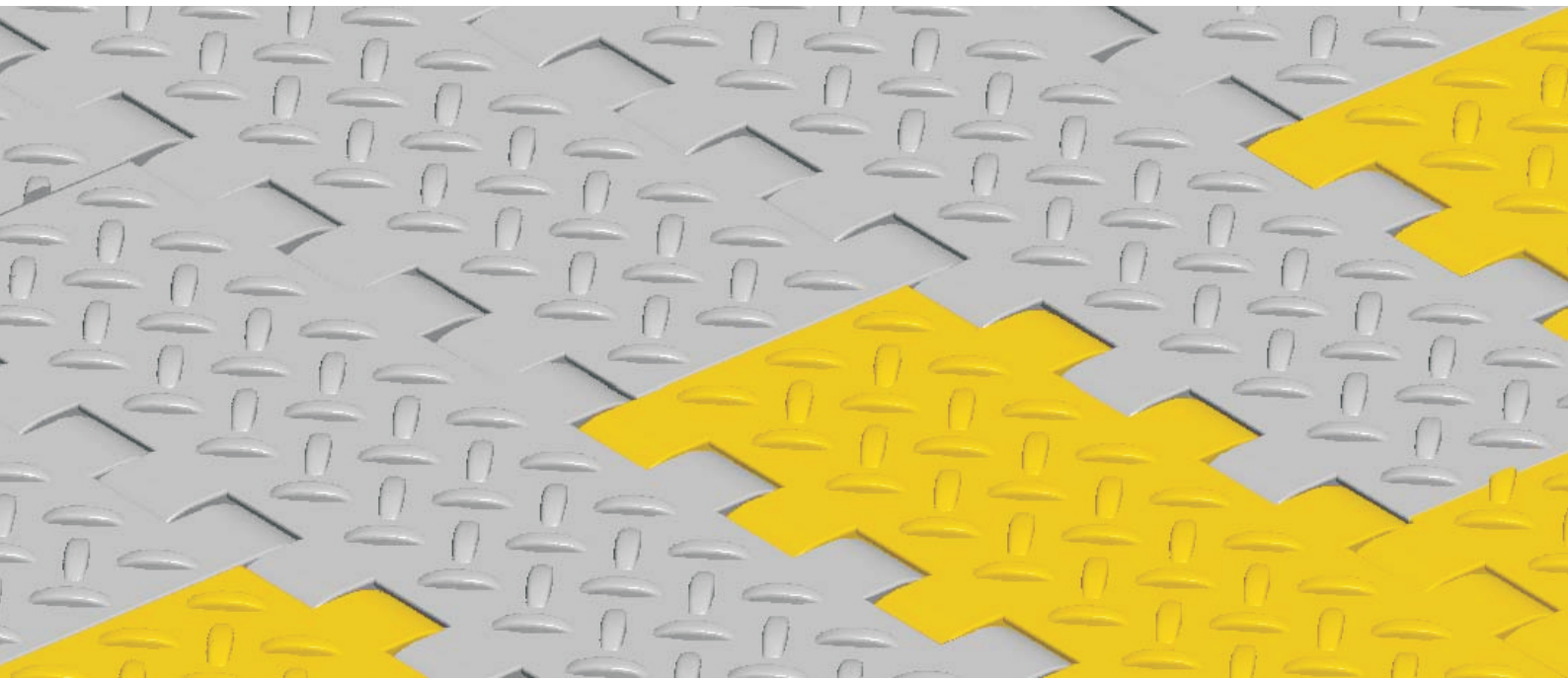

Pitch: 63.5mm Minimum Width: 200mm Open Area: 0% Approved: FDA Stainless steel Rod: Ø 10mm Flight: No Side Guard: No Curve: No	
---	--

Data

Belt Material	Belt Strength		Curve	Temperature		Belt Weight (Kg/M ²)
	Straight			°C (min.)	°C (max.)	
	Kg/M(BW)	N/M(BW)				
Acetal	10000	100000	--	-40	80	33.3
Acetal+ AS	10000	100000	--	-40	85	33.3

BW – Belt Width **AS** –Anti-Static

Color Table

Polypropylene					Polyethylene					Acetal				
W	G	N	DB	B	W	G	N	DB	B	W	G	N	BL	B
										●			●	●

W-White, G-Gray, N-Nature, DB-Darkbrown, B-Blue

Friction Table

Belt Material	Friction Wear strips & Products							
	UHMW	HDPE	Steel	Glass	SUS	Plastic	Cardboard	Aluminum
Polypropylene	0.32	0.24	0.15	0.09	0.13	0.08	0.15	0.25
Polyethylene	0.13	0.11	0.26	0.19	0.31	0.16	0.21	0.41
Acetal	0.11	0.09	0.27	0.16	0.26	0.15	0.19	0.28

SUS – Stainless Steel

Equivalent type with other Brand

Brand Name	Intralox	UNI	Rexnord	MCC	Habasit	KVP
Series & Type	1800	XLB	2500		M6300	
			3120		M6400	

The above content is only for reference.

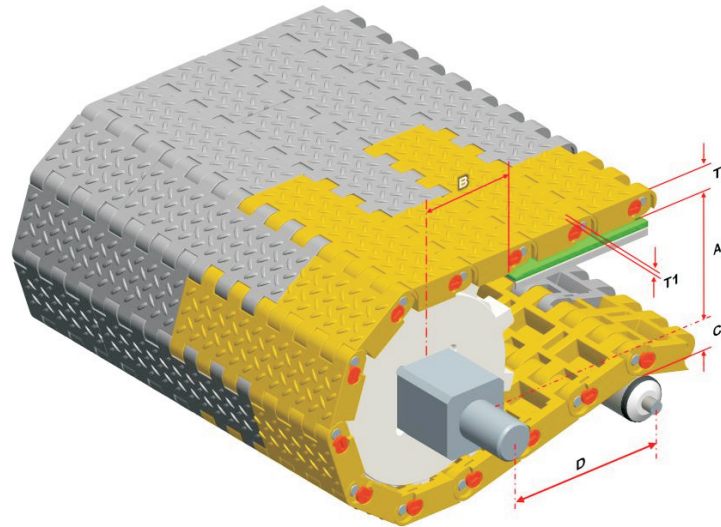

Conveyor Frame Dimensions

Unit: mm

No. Teeth	A (Min.)	B (Min.)	C (Max.)	D (Min.)	T	T1
10	88.25	110.75	79.75	400	25	1.5
13	118	140.5	109.5	450		
15	141.5	164	133	500		

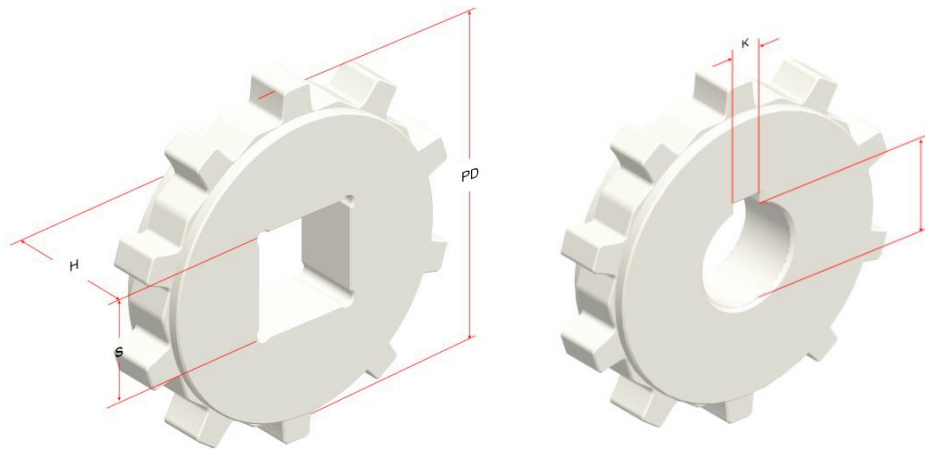

Sprocket Dimensions

Unit: mm

No. Teeth	PD	S	D	H	K
10	201.5	60.3/63.5/82.5	60.25	36	18x4
13	261	63.5/80.5/100.2	--	36	--
15	308	90.5	--	36	--

⌘ The above sprockets are standard, and it also can be customized according to customer's request, including the teeth number of sprocket and the size of square bore; the processing time is about 2 weeks.