

# HS-100C Technical Data Sheet

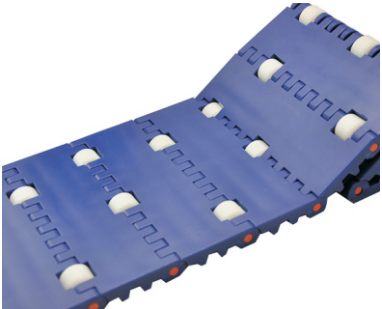

Pitch: 50.8mm  
 Minimum Width: 150mm  
 Open Area: 0%  
 Approved: FDA  
 Rod: Ø 5.8mm  
 Flight: No  
 Side Guard: No  
 Curve: No

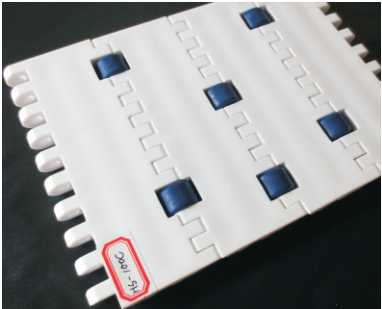
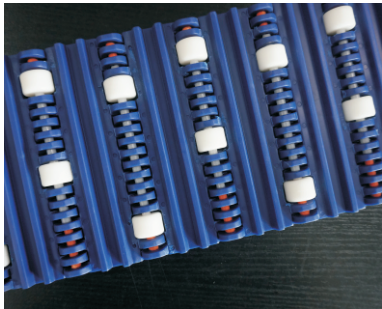
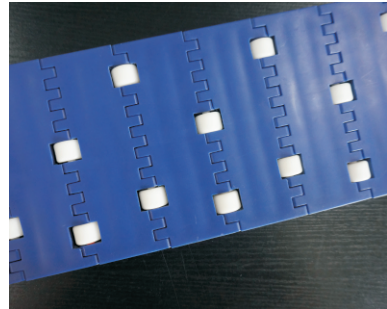
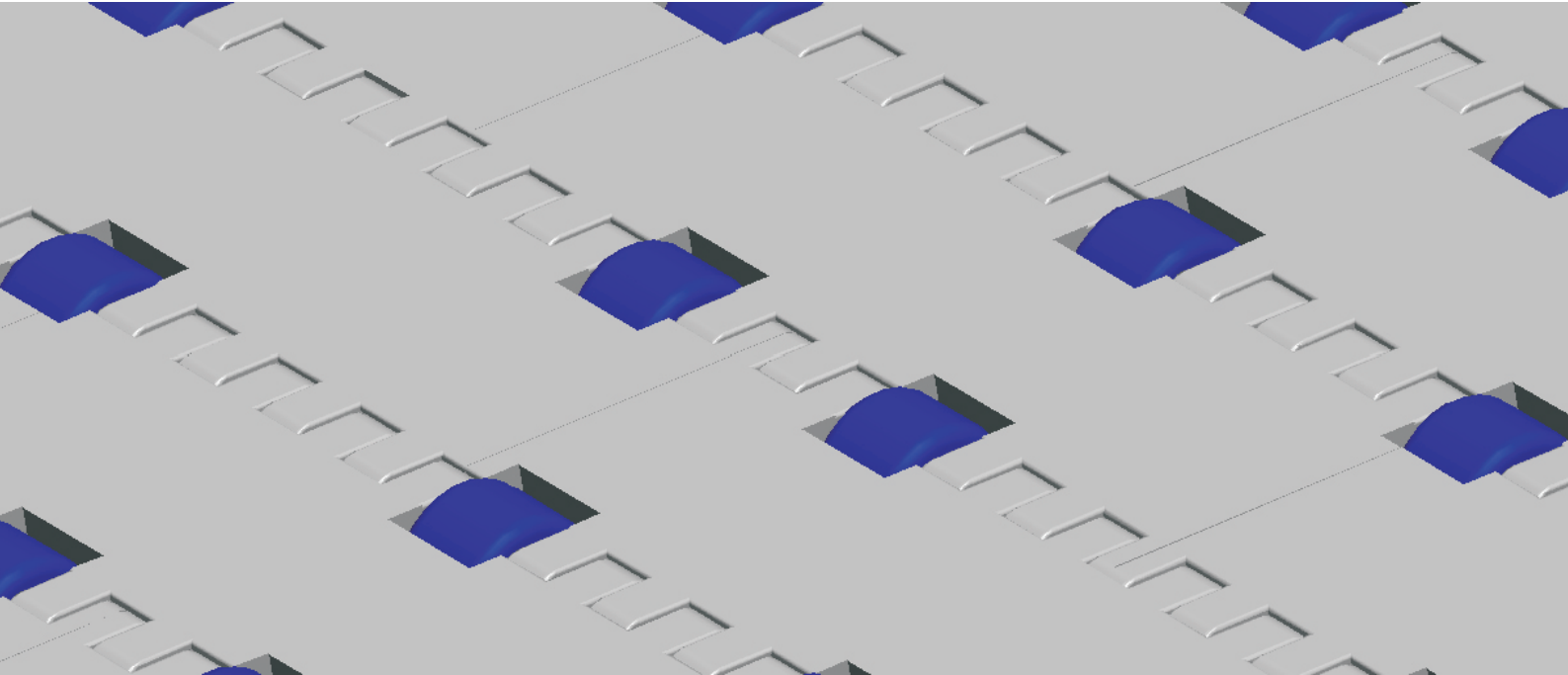
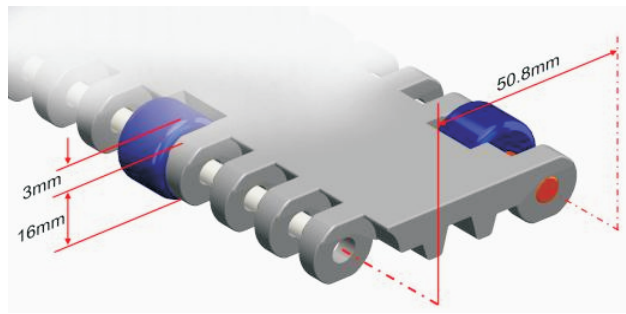

## Data

Belt Material	Belt Strength			Temperature		Belt Weight
	Straight		Curve	°C (min.)	°C (max.)	(Kg/M <sup>2</sup> )
	Kg/M(BW)	N/M(BW)				
Polypropylene	1340	13400	--	1	100	8.9
Polyethylene	1280	12800	--	-60	60	9.8
Acetal	1770	17700	--	-40	80	13.8
Nylon	1520	15200	--	1	180	11.9

**BW – Belt Width**

## Color Table

Polypropylene					Polyethylene					Acetal					Nylon				
W	G	N	DB	B	W	G	N	DB	B	W	G	N	DB	B	W	G	N	DB	B
●	●						●			●				●				●	

W-White, G-Gray, N-Nature, DB-Darkbrown, B-Blue

## Friction Table

Belt Material	Friction Wear strips & Products							
	UHMW	HDPE	Steel	Glass	SUS	Plastic	Cardboard	Aluminum
Polypropylene	0.32	0.24	0.15	0.09	0.13	0.08	0.15	0.25
Polyethylene	0.13	0.11	0.26	0.19	0.31	0.16	0.21	0.41
Acetal	0.11	0.09	0.27	0.16	0.26	0.15	0.19	0.28
Nylon	0.18	0.13	0.25	0.16	0.26	0.16	0.19	0.27

SUS – Stainless Steel

## Equivalent type with other Brand

Brand Name	Intralox	UNI	Rexnord	MCC	Habasit	KVP
Series & Type	200	OPB	6390	2000	H5000	620
	800/850	L-SNB	2010		M5100	
	400	MPB	2000			

The above content is only for reference.

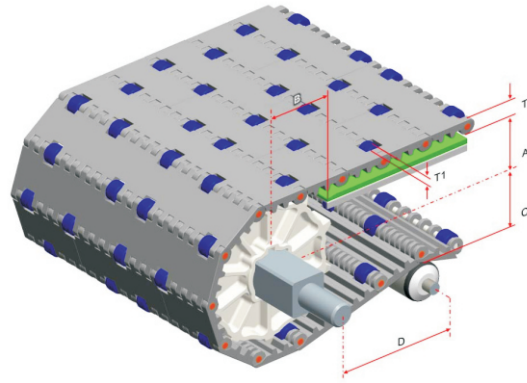

**Conveyor Frame Dimensions**

Unit : mm

No. Teeth	A ( Min.)	B ( Min.)	C ( Max.)	D ( Min.)	T	T1
6	37.9	55.9	33.9	250	16	3
8	56	74	52	250		
9	63.5	81.5	59.5	250		
10	73	91	69	250		
12	88.4	106.4	84.4	300		
16	122	140	118	300		

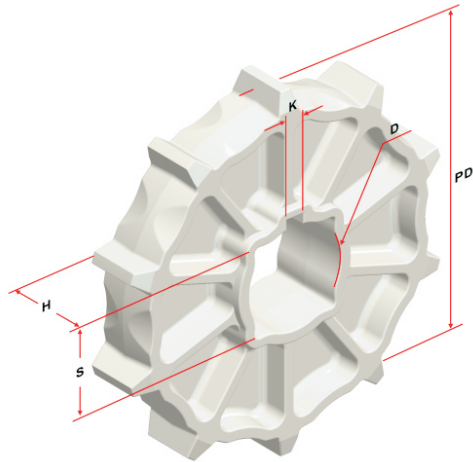

**Sprocket Dimensions**

Unit: mm

No. Teeth	PD	S	D	H	K
6	91.8	38.5/40.5	25.5/30.5/35.5/45.5	30	8X8
8	128	38.5/40.5	25.5/30.5/35.5/40.5/44.5	37	7X7
9	143	38.5/40.5	32.5/45.5/51	35	8X8
10	162	38.5/40.5/50.5/60.5	25.5/30.5/35.5/40.5/45.5	35	8X8
12	192.8	38.5/40.5/60.5	45.5/47.5	37	8X8
16	260	38.5/60.5/63.5	--	46	--

### Support Mode of Insert Roller

⌘ Accumulation

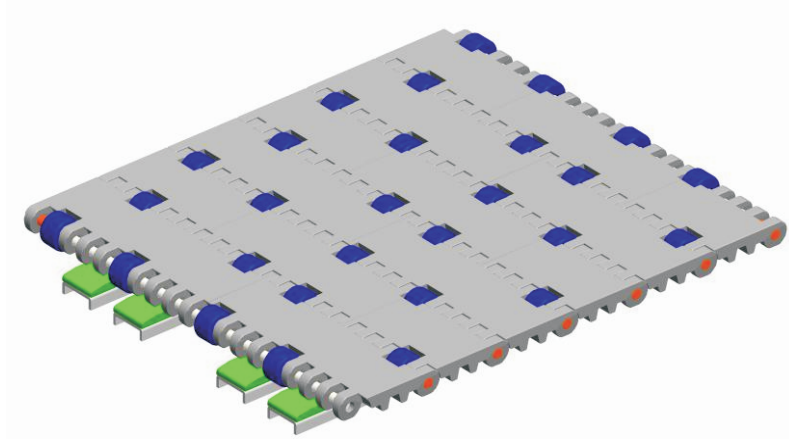

Wear Strips are placed between rollers for accumulation.

⌘ Multi-Speed

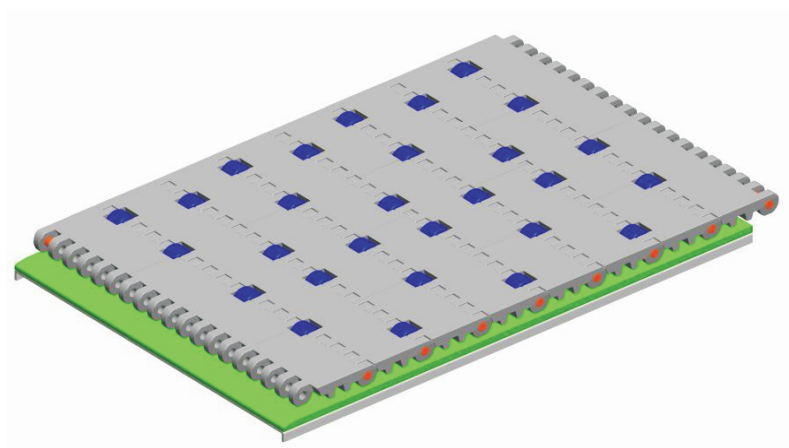

Wear Strips are placed under the rollers and the speed of products on the belt will be 2 times of the belt speed.